

UCR100

UHF Multi-Frequency Compact Receiver



Fill in for your records:

Serial Number:

Purchase Date:

Introduction

Thank you for selecting the Lectrosonics multi-frequency, UCR100 Receiver. The UCR100 is the result of extensive engineering experience with the very latest microprocessor advancements and technology.

The Lectrosonics 100 System Receiver and companion transmitter are designed expressly for the most discriminating videographer and for other wireless applications needing superior audio quality, flexible operation, and outstanding durability. The compact size of the receiver provides ease of integration with most any compact video camera.

Table of Contents

Introduction	3
General Technical Description	4
Features	4
Dual Band Compador	4
UCR100 Block Diagram	4
Pre-Emphasis/De-Emphasis.....	4
Controls & Functions	5
Modulation LEDs.....	5
Power ON/OFF Switch.....	5
Power LED	5
RF LED	5
Audio Out Jack.....	5
Audio Level Control.....	6
Antenna.....	6
Frequency Select Switches.....	6
Operating Instructions	7
Indicator Quick Reference.....	7
Battery Instructions	7
Troubleshooting	8
Specifications and Features	9
Service and Repair	10
Returning Units for Repair	10

General Technical Description

Features

The multi-frequency UCR100 FM Receiver is designed to operate with the Lectrosonics UM100 Transmitter and features microprocessor control of 256 frequencies of operation within each frequency block. Each block covers 25.5 MHz with 0.1 MHz frequency spacing. Any one of ten different frequency blocks are factory available from 537.6 MHz to 805.5 MHz (except 608 to 614 MHz).

The receiver's unique microcontroller design provides simple operation for audio level/limit LED monitoring, RF level LED monitoring, squelch, easy on-the-fly frequency programming and low battery warning. The UCR100 Receiver uses 20 kHz FM deviation for efficient use of the bandwidth and dual band companding for clean quiet audio. The receiver operates on one 9 Volt alkaline battery for up to 8 hours and features a blinking LED low battery indicator. The voltages are internally regulated for stability. The receiver is housed in a compact, rugged, lightweight aluminum enclosure. The unit features a durable integral swing-aside battery compartment door.

Dual Band Compandor

Traditionally, compandors have been a source of distortion in wireless microphone systems. The basic problem with conventional systems is that the attack and decay times are always a compromise. If the time constants are fast, high frequency transients will not be distorted, but this will cause low frequency distortion. If the time constants are slower, low frequency audio distortion will be low, but high frequency transients will then be distorted.

The 100 system introduces the proven Lectrosonics approach to solving this basic problem, called "dual-band companding."

There are actually two separate compandors in the 100 system, one for high frequencies and one for low frequencies. A crossover network separates the frequency bands at 1kHz with a 6dB per octave slope, followed by separate high and low frequency compandors. The attack and release times in the high frequency compandor are fast enough to keep high frequency transient distortion at a low level, and the low frequency compandor uses slower time constants, reducing low frequency distortion to well below that of a conventional compandor.

Pre-Emphasis/De-Emphasis

The signal to noise ratio of the 100 system is extended by utilizing pre-emphasis (HF boost) in the transmitter and de-emphasis (HF roll off) in the receiver. Pre-emphasis and de-emphasis in an FM radio system usually provides about a 10dB improvement in the signal to noise ratio of the system, but the high frequency boost in the transmitter must be removed in a purely complementary manner or else the frequency response of the original audio signal will be altered.

The dual-band compandor in the 100 Series system essentially provides a dynamic pre-emphasis/de-emphasis function with low distortion.

UCR100 Block Diagram

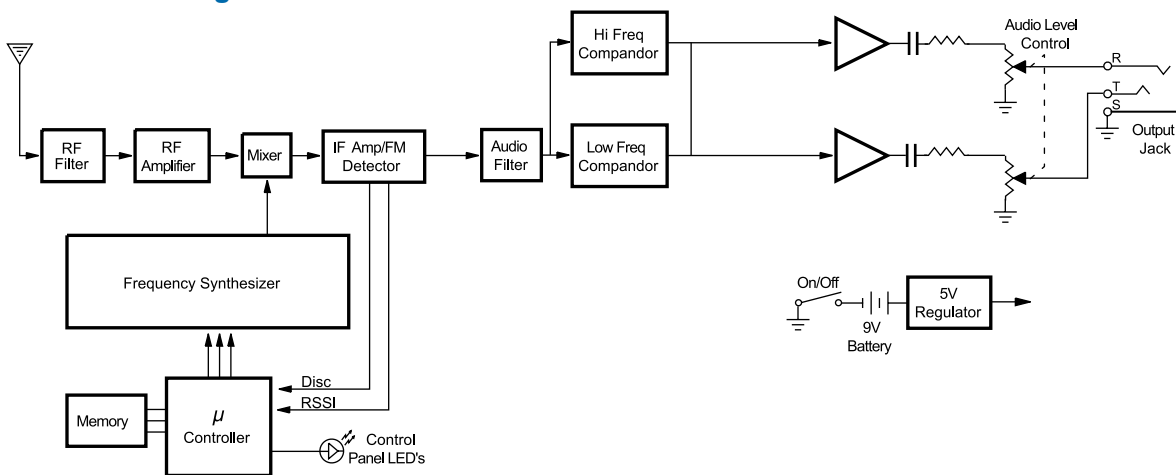

Controls & Functions

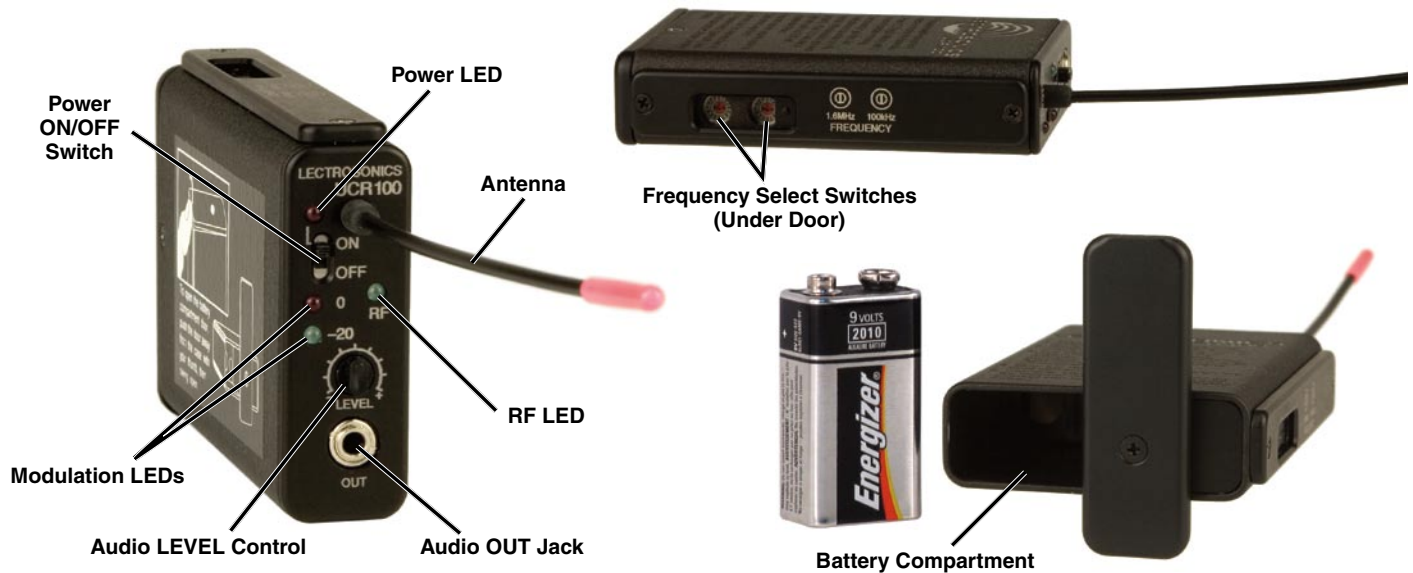

Modulation LEDs

The two modulation LED's indicate the modulation (audio level) of the incoming signal and can be used for proper adjustment of the transmitter's mic or audio level.

The -20 LED glows when the transmitter modulation is at a high enough level to produce a good audio signal-to-noise ratio. It will normally flicker, or stay lit as you speak into the microphone. The 0 dB lamp indicates a "peak," showing that the transmitter modulation is at maximum. Constant lighting of the 0 dB LED indicates that the audio gain in the transmitter may be set too high. It is normal and desirable that you see an occasional flicker of the 0 dB lamp in typical use.

Power ON/OFF Switch

Turns the receiver on or off.

Power LED

The Power LED glows when the power switch is in the ON position and the battery is good. The power LED starts blinking when the battery is becoming exhausted and needs replacement. If the LED does not light up when the switch is turned on or during operation, replace the battery. In normal operation a new alkaline battery will operate the receiver approximately 5 hours before the LED starts blinking and will continue operating for approximately another 3 hours before the LED goes off. At that point the unit and the other LED's will continue operating for another hour or so but with some degradation in performance. During the low battery blinking period the LED on time decreases as the battery becomes depleted. See the chart in Battery Instructions.

The battery level is precision monitored by the internal microprocessor which also drives the Power LED for accurate battery condition.

IMPORTANT! When the battery voltage drops below 6 Volts, the power LED will remain off, but the other 3 LEDs will light up and a rush of audio noise and distortion will be heard as the squelch opens. This condition is normal, and is easily remedied by replacing the battery.

RF LED

Lights when the transmitter is turned on and the receiver has a strong RF signal. The RF LED will start blinking when the RF carrier signal from the transmitter becomes too weak to produce a clean audio signal. The lamp will go out completely when the RF signal is absent or extremely weak.

Audio Out Jack

The 3.5mm mini phone jack provides an audio output that is controlled by the Audio LEVEL control on the front panel. Generally, the Audio LEVEL control would be set to provide the proper output level to match the required level for your video camera or other equipment.

The 3.5mm mini jack will accommodate a mono plug (tip & sleeve) or a stereo type jack (tip/ring & sleeve) without harm to the unit. When using a pair of stereo headphones the audio will be mono but will drive both earphones in the correct (binaural) phase.

The output at this mini connector jack is designed to also drive a standard impedance earphone, typically 30 Ohms (most common) and usually provides adequate volume for setup and testing. The sound from a low impedance ear phone (ie. 8 Ohms) will not be very loud and may be distorted at higher listening levels.

Audio Level Control

Attenuates the audio output level of the receiver to match the input requirements of the equipment with which it is used. The 3.5mm Mini output jack on the front panel provides an audio output at adjustable levels for low or high impedance, unbalanced inputs. At the extreme counter-clockwise position of the control knob, the output level of the Mini jack will be -50dBV at full modulation. In the fully clockwise position, the output level will be 0dBV (1 Vrms) at full modulation. Intermediate settings are sometimes necessary due to the variations in different input compressors and ALC (automatic level control) circuits on various VCR's and audio inputs. The markings around the control knob are provided simply as "memory markers;" they are not calibrated with reference to a specific output level.

Antenna

The antenna is a 1/4 wavelength 50 ohm flexible non-removable antenna made of durable sheathed bronze wire.

Frequency Select Switches

These two rotary switches adjust the center frequency of the carrier. The 1.6M is a coarse adjustment and the 100K is the fine adjustment. Each transmitter is factory aligned at the center of its operating range. The default position of the frequency select switches is in the center of the transmitter's range. The receiver and transmitter switches must be set to the same number/letter combination for proper operation.

To gain access to these switches, slide the access door sideways with a fingernail.

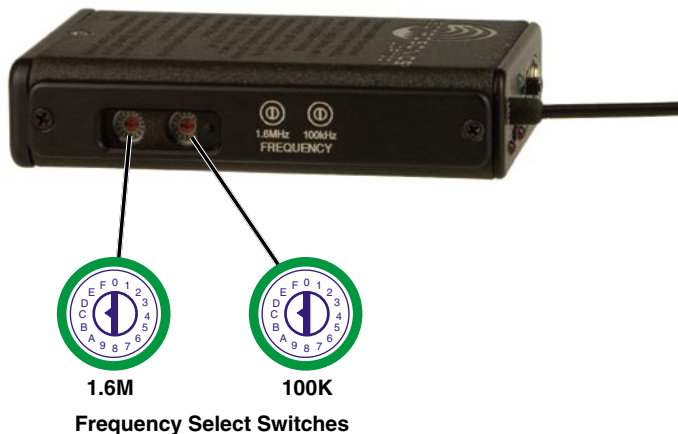

Operating Instructions

1. Install the battery.
2. Set the "FREQUENCY" switches on the side panel to match the switches on the Transmitter.
3. Connect the audio cable.
4. Set the front panel switch to ON. Check to see that the red POWER LED lights up.
5. **THIS IS PERHAPS THE MOST IMPORTANT STEP IN THE SET UP PROCEDURE.** Adjust the transmitter "gain". See your transmitter manual (Operating Instructions section) for specific directions on the proper gain adjustment of your particular transmitter.
6. Adjust the output control according to the type of input on your equipment. The input levels on different VCR's and PA equipment vary, which may require that you set the output LEVEL control in an intermediate position. Try different settings and listen to the results. If the output of the receiver is too high, you may hear distortion or a loss of the natural dynamics of the audio signal. If the output is too low, you may hear steady noise (hiss) along with the audio. The UCR100 output was designed to drive camera line level inputs but can operate into camera MIC inputs if the receiver output is reduced to prevent Automatic Limiting Control "pumping" in the camera. The output signal level ranges from -50 dBV with the output control fully counter clockwise to 0 dBV with the output control fully clockwise when the transmitter signal is at full modulation.

Indicator Quick Reference

RF - This LED lights up when the transmitter is turned on. This indicates that the receiver is getting an adequate RF signal (carrier) from the transmitter.

POWER - This LED lights up when the receiver is switched on. It indicates proper battery voltage when the receiver is using a battery. See chart in Battery Instructions.

MODULATION - The "-20" LED lights up when an audio signal is present at an adequate level to produce a good signal to noise ratio. The "0dB" LED lights up when the audio level is high and the signal is being compressed in the transmitter. An extremely high audio level may cause distortion.

Battery Instructions

The battery should be a 9 Volt alkaline or lithium, available almost everywhere. An alkaline battery will provide up to 8 hours of operation and a lithium battery will provide up to 20 hours of operation. Carbon zinc batteries, even if marked "heavy duty" will only provide about 2 hours of operation. Rechargeable batteries will only operate the receiver for an hour or less. Make sure your batteries are marked "*alkaline*" or "*lithium.*" Short battery life is almost always caused by weak batteries or batteries of the wrong type.

A steady "ON" LED corresponds to a fresh battery. The LED will blink to indicate a low battery condition and the need for a fresh battery. Continued use will further deplete the battery eventually causing the LED to automatically turn itself off and remain off until a fresh battery is installed.

To replace the battery, open the bottom battery door cover with your thumb, rotate the door until it is perpendicular with the case and allow the battery to fall out of the compartment into your hand. Observe the large and small holes in the battery contact pad before inserting a new battery. Insert the contact end of the battery first, making sure the contacts are aligned with the holes in the contact pad, and then swing the door closed. You will feel it snap into place when it is fully closed.

Hours	Power LED
1	Solid On
2	Solid On
3	Solid On
4	Solid On
5	Solid On
6	Blinks 90% on, 10% off
7	Blinks 50% on, 50% off
8	Blinks 10% on, 90% off
9	Off (Replace battery)

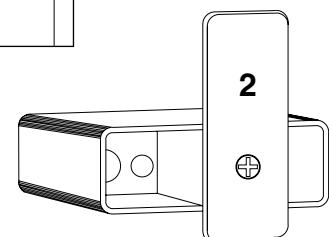
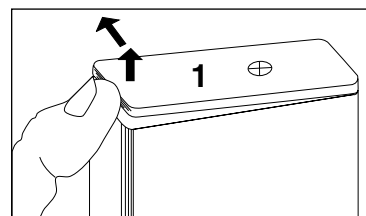

Troubleshooting

Before going through the following chart, be sure that you have a good battery in the receiver.
The POWER LED should glow brightly.

SYMPTOM

POSSIBLE CAUSE

NO POWER LED

- 1) Receiver switch in "OFF" position
- 2) Dead or weak battery
- 3) Battery missing
- 4) Battery installed backwards

NO RF LED

- 1) Transmitter not turned on
- 2) Transmitter battery dead
- 3) No microphone on the transmitter
- 4) Receiver antenna positioned incorrectly
- 5) Transmitter and Receiver on different frequencies
(FREQUENCY switches do not match transmitter switches)

RF LED ON BUT NO SOUND AND NO MODULATION LEDs

- 1) Transmitter audio level set to low
- 2) Transmitter microphone not connected
- 3) Microphone switch in "OFF" position
- 4) Check transmitter modulation LEDs for possible transmitter problem

MODULATION LED's ON BUT NO SOUND

- 1) Receiver LEVEL control turned down
- 2) Audio cable disconnected
- 3) Recorder or sound system off or not properly adjusted

DISTORTED SOUND

- 1) Transmitter Audio Level set too high
(check mod lamps on Transmitter)
- 2) Weak battery

SHORT RANGE

- 1) Transmitter or receiver antenna not clear of obstructions

HISS AND NOISE -- AUDIBLE DROPOUTS

- 1) Transmitter gain (audio level) far too low.
- 2) Receiver antenna obstructed or damaged.
- 3) Transmitter antenna obstructed or damaged.
- 4) Operating range too great.

HISS AND NOISE – PUMPING

- 1) Camera or recorder has automatic level control. Use line level input on camera or recorder. If there is only a mic input, reduce the receiver output to near minimum.

Specifications and Features

Operating frequencies:	537.6 to 608 MHz, 614 to 793.5 MHz (in 10 blocks)
Number of frequencies:	256 per block (using 26 MHz wide band)
Channel spacing:	100 kHz
Frequency control:	Crystal Controlled Phase Locked Loop
Sensitivity:	1 uv (20 dB SINAD)
Signal/Noise ratio:	105 dB (system)
Squelch quieting:	90 dB
AM rejection:	50 dB, 10 uv to 100 mv
Modulation acceptance:	+/-20 kHz
Spurious rejection:	Greater than 70 dB
Third order intercept:	0 dBm
Frequency response:	50 Hz to 18 kHz, (± 2 db)
Distortion:	1% max at 50% modulation (system)
Audio output:	0 dBv (1 Vrms) UNBALANCED into 600 ohms
Antenna:	1/4 wave vertical (fixed)
Front panel controls:	Single knob controls Audio Output Level
LED Indicators:	Power (red), RF (green), Level (green), Limit (red)
Power requirement:	Single 9V Alkaline Battery for approximately 8 hours operation.
Power consumption:	60 ma.
Weight:	7.3 oz with battery
Size:	3.6 x 2.4 x 0.8 inches (housing only, belt clip and knob extend beyond the housing.)

Specifications subject to change without notice.

Service and Repair

If your system malfunctions, you should attempt to correct or isolate the trouble before concluding that the equipment needs repair. Make sure you have followed the setup procedure and operating instructions. Check the interconnecting cables and then go through the **Troubleshooting** section in this manual.

We strongly recommend that you **do not** try to repair the equipment yourself and **do not** have the local repair shop attempt anything other than the simplest repair. If the repair is more complicated than a broken wire or loose connection, send the unit to the factory for repair and service. Don't attempt to adjust any controls inside the units. Once set at the factory, the various controls and trimmers do not drift with age or vibration and never require readjustment. **There are no adjustments inside that will make a malfunctioning unit start working.**

Lectrosonics' Service Department is equipped and staffed to quickly repair your equipment. In warranty repairs are made at no charge in accordance with the terms of the warranty. Out-of-warranty repairs are charged at a modest flat rate plus parts and shipping. Since it takes almost as much time and effort to determine what is wrong as it does to make the repair, there is a charge for an exact quotation. We will be happy to quote approximate charges by phone for out-of-warranty repairs.

Returning Units for Repair

For timely service, please follow the steps below:

- A.** DO NOT return equipment to the factory for repair without first contacting us by email or by phone. We need to know the nature of the problem, the model number and the serial number of the equipment. We also need a phone number where you can be reached 8 A.M. to 4 P.M. (U.S. Mountain Standard Time).
- B.** After receiving your request, we will issue you a return authorization number (R.A.). This number will help speed your repair through our receiving and repair departments. The return authorization number must be clearly shown on the **outside** of the shipping container.
- C.** Pack the equipment carefully and ship to us, shipping costs prepaid. If necessary, we can provide you with the proper packing materials. UPS is usually the best way to ship the units. Heavy units should be "double-boxed" for safe transport.
- D.** We also strongly recommend that you insure the equipment, since we cannot be responsible for loss of or damage to equipment that you ship. Of course, we insure the equipment when we ship it back to you.

Lectrosonics USA:

Mailing address:

Lectrosonics, Inc.
PO Box 15900
Rio Rancho, NM 87174
USA

Shipping address:

Lectrosonics, Inc.
581 Laser Rd.
Rio Rancho, NM 87124
USA

Telephone:

(505) 892-4501
(800) 821-1121 Toll-free
(505) 892-6243 Fax

Web:

www.lectrosonics.com

E-mail:

sales@lectrosonics.com

Lectrosonics Canada:

Mailing Address:

49 Spadina Avenue,
Suite 303A
Toronto, Ontario M5V 2J1

Telephone:

(416) 596-2202
(877) 753-2876 Toll-free
(877-7LECTRO)
(416) 596-6648 Fax

E-mail:

Sales: colinb@lectrosonics.com
Service: joeb@lectrosonics.com

LIMITED ONE YEAR WARRANTY

The equipment is warranted for one year from date of purchase against defects in materials or workmanship provided it was purchased from an authorized dealer. This warranty does not cover equipment which has been abused or damaged by careless handling or shipping. This warranty does not apply to used or demonstrator equipment.

Should any defect develop, Lectrosonics, Inc. will, at our option, repair or replace any defective parts without charge for either parts or labor. If Lectrosonics, Inc. cannot correct the defect in your equipment, it will be replaced at no charge with a similar new item. Lectrosonics, Inc. will pay for the cost of returning your equipment to you.

This warranty applies only to items returned to Lectrosonics, Inc. or an authorized dealer, shipping costs prepaid, within one year from the date of purchase.

This Limited Warranty is governed by the laws of the State of New Mexico. It states the entire liability of Lectrosonics Inc. and the entire remedy of the purchaser for any breach of warranty as outlined above. NEITHER LECTROSONICS, INC. NOR ANYONE INVOLVED IN THE PRODUCTION OR DELIVERY OF THE EQUIPMENT SHALL BE LIABLE FOR ANY INDIRECT, SPECIAL, PUNITIVE, CONSEQUENTIAL, OR INCIDENTAL DAMAGES ARISING OUT OF THE USE OR INABILITY TO USE THIS EQUIPMENT EVEN IF LECTROSONICS, INC. HAS BEEN ADVISED OF THE POSSIBILITY OF SUCH DAMAGES. IN NO EVENT SHALL THE LIABILITY OF LECTROSONICS, INC. EXCEED THE PURCHASE PRICE OF ANY DEFECTIVE EQUIPMENT.

This warranty gives you specific legal rights. You may have additional legal rights which vary from state to state.

